

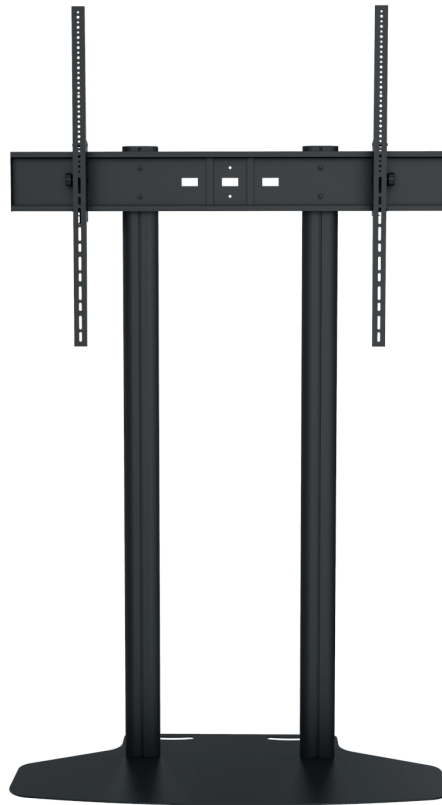

Ready when you are.

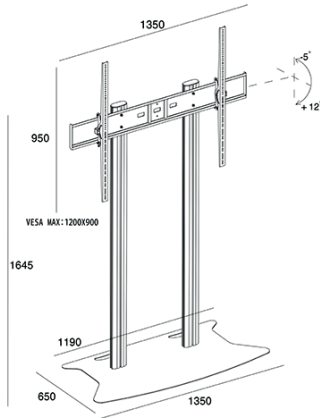

# M Display Stand 180 Dual Pillar Flight Case

Art No: 7 350 073 731 060

Multibrackets Dual Pillar floor stand is a unique solution targeting audiences anywhere. Delivered in a wheel based flight case and holding screens up to 110" or 125 Kg's it is built to last. If you need a floor stand with fast assembling and easy to disassemble this might

just be the product you need. All peripherals needed to assemble this unit is neatly packed into the flight case. We even put in some extra products if some items are lost when the product is moved from location to location.

## SPECIFICATIONS

M Display Stand 180 Dual Pillar Flight Case Black	
For screen size:	70-110"
VESA standard:	Up to 1200x900 mm
EAN:	7 350 073 731 060
Size in mm: (WxDxH)	1350x650x1645 mm
Adjustable height:	Yes
Weight:	53 kg w/o flight case
Colour:	Black
Max load:	125 kg
DVD Shelf / Camera holder:	Optional
Power rail 220V:	No
Package size:	available in a moment
Warranty:	5 years

