

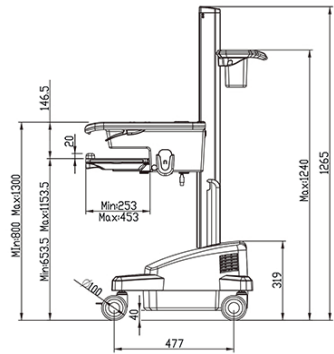

Ready when you are.



M Universal Workstation Cart NB/ UPS

Art No: 7 350 073 730 957

Multibrackets unique carts fits most notebooks and personal computer displays on the market. Multibrackets carts are space efficient, light weight and easy to maneuver in tight areas. Examples of places where it might be extra suitable is in a patient, emergency & operating rooms, labs, radiology, nurse stations – or wherever patient data or a maneuverable workstation might be in need. 475x475x302 base makes the carts

very easy to maneuver in tight areas. With its 31kg on high quality and silicon covered castors moving it around is a breeze. As all the units contact surfaces are finished with anti microbial materials delivering an ultra smooth & safe surface it is especially suitable at patient rooms, emergency & operating rooms, labs, radiology, nurse stations etc.

SPECIFICATIONS

M Universal Workstation Cart NB/ UPS

For notebook screen-sizes: 9,7 - 17,3"

Feature: Highly customizable and bacteria free work surfaces

VESA: Using a notebook screen as display VESA not required

EAN: 7 350 073 730 957

Product materials: Plastic/ Steel/ Silicone

Unit Size: 549x727x1265 (WxDxH)

Base Size: 475x475x302 (WxDxH)

Adjustable height/ Tilt: Height adjustable by rail

Pillar adjustability: 500mm up and down

Max load: 7,5 kg

Weight: 68 kg

Color: Silver and white

Shelf: Extra shelf optional

Power: Built in battery pack/UPS. Built in USB fan for better circulation

Package size: W800xD640xH1450 mm

Keyboard tray: Yes

Mouse tray: Yes

Scanner holder: Yes

Key lock: Yes to CPU compartment

Castors/ Wheels: Included, 2 front is lockable

Mount to floor: No

Warranty: 1 year

